







# EC SERİSİ

STEEL BASE LEVELLING FEET  
ÇELİK GÖVDE DENGE AYAKLARI

## BAĞLANTI ŞEKİLLERİ

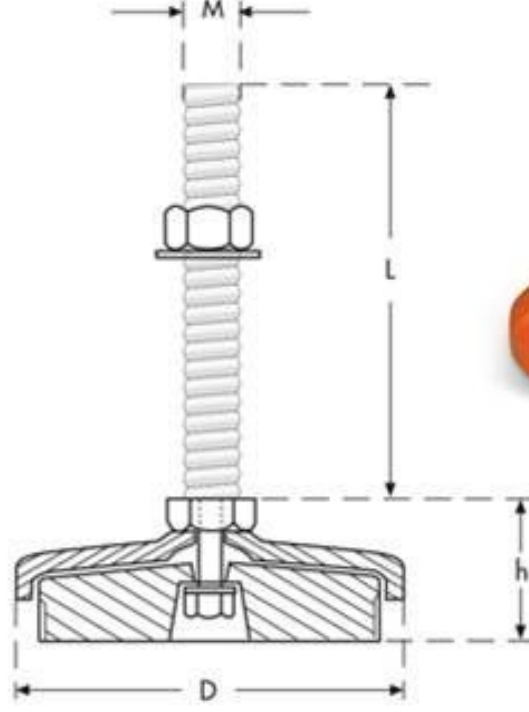
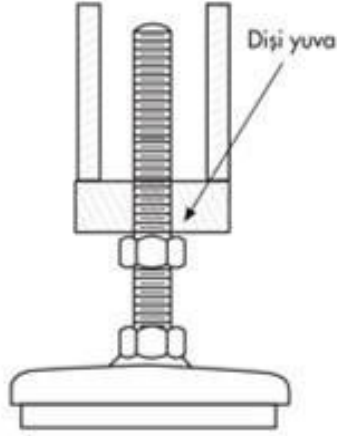
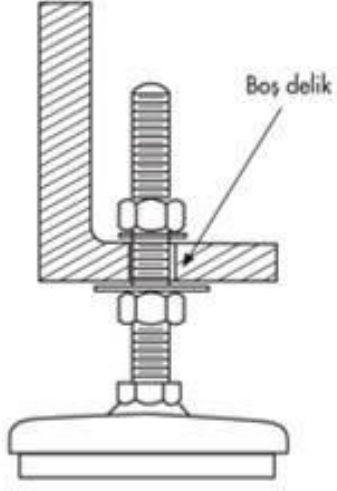

- Taşıyıcı taban RAL 2004 elektrostatik boyalı çelik malzeme.
- Bağlantı civatası beyaz çinko kaplamalıdır.
- Kaymayı önleyen siyah kauçuk ped.

- Painted steel base with anti-slip rubber.
- Galvanized iron bolt.

KOD Code	D (mm)	M	L (mm)	H (mm)	.....	Taşıma kg / adet Load kg/pcs.
EC 50 1050	50	M10x50	50	32		400
EC 50 1250	50	M12x50	50	32		500
EC 50 1610	50	M16x100	100	32		600
EC 10 1610	100	M16x100	100	35		1.200
EC 10 1615	100	M16x150	150	35		1.200
EC 10 2015	100	M20x150	150	37		1.500
EC 10 2415	100	M24x150	150	37		2.000
EC 15 1610	150	M16x100	100	35		2.000
EC 15 1615	150	M16x150	150	35		2.000
EC 15 2015	150	M20x150	150	37		3.000
EC 15 2415	150	M24x150	150	37		4.000
EC 20 1610	200	M16x100	100	35		4.000
EC 20 1615	200	M16x150	150	35		4.000
EC 20 2015	200	M20x150	150	37		5.000
EC 20 2415	200	M24x150	150	37		6.000





# ES SERİSİ

MACHINE ANTI-VIBRATION MOUNTS  
MAKİNA TİTREŞİM TAMPONLARI



ES 3



ES 1



ES 2

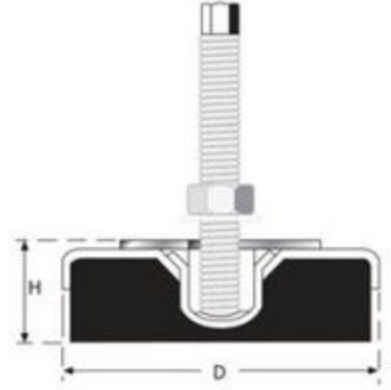

## AVANTAJLARI

- Titreşim ve ortam gürültüsünü azaltır.
- Pratik makine terazilemesini sağlar.
- Yere bağlantı gerektirmez, makine yürümelerini engeller.
- Kolay montaj ve makine yer değiştirme sağlar.
- Kauçuk tabanı, madeni yağlar, mazot, gres yağları, mazot ve bazı asitlere karşı yüksek dayanımlıdır.

## KULLANIM ALANLARI

Takım tezgahları, enjeksiyon makineleri, paketleme, matbaa, baskı, test makineleri, tekstil, gıda, ambalaj, mermer ve ağaç işleme makine ve ekipmanlarında kullanılabilir.

## MODEL SEÇİMİ

Makine ağırlığı / montaj ayak sayısı = taşıma Kg/ad.

## ADVANTAGES

- Vibration reduction.
- Easy leveling for machines.
- No anchor bolts to the floor, prevention of machine walking.
- Easy and quick installation.
- Rubber base in high resistance to oils, acids, grease, etc.

## APPLICATIONS

Milling, moulding, printing, stamping machines, wood working machines, packaging equipments, lathes, grinders, presses, die casting, band saws etc.

## SELECT TO MOUNTS

Total machine weight / number of machine supports = load capacity kg/pcs.

KOD Code	D (mm)	Civata Bolt	Civata Boyu Bolt Length	H (mm)	Ayar Mesafesi Leveling Adj.	Taşıma kg / adet Load kg/pcs.
ES1	80	M12 x 1.25	120	45	12	500
ES1/A	80	M16 x 1.5	120	45	12	500
ES1/B	80	M10 x 1.5	100	45	12	500
ES2	120	M16 x 1.5	120	45	15	1.000
ES2/A	120	M12 x 1.25	120	45	15	1.000
ES2/B	120	M16 x 2	120	45	15	1.000
ES3	160	M16 x 1.5	120	54	15	2.000
ES4	160	M20 x 1.5	170	55	15	4.000
ES5	200	M20 x 2.5	170	55	25	5.000
ES6	200	M24 x 3	170	55	25	6.000
ES7	240	M20 x 2.5	170	65	25	7.000
ES7/A	240	M24 x 3	170	65	25	8.000
ES7/B	240	M30 x 3	170	65	25	9.000



# M SERİSİ

MACHINE ANTI-VIBRATION MOUNTS  
MAKİNA TİTREŞİM TAMPONLARI



## AVANTAJLARI

- Titreşim ve ortam gürültüsünü azaltır.
- Pratik makine terazilemesini sağlar.
- Yere bağlantı gerektirmez, makine yürümelerini engeller.
- Kolay montaj ve makine yer değiştirme sağlar.
- Kauçuk tabanı, madeni yağlar, mazot, gres yağları, mazot ve bazı asitlere karşı yüksek dayanımlıdır.

## KULLANIM ALANLARI

Takım tezgahları, enjeksiyon makineleri, paketleme, matbaa, baskı, test makineleri, tekstil, gıda, ambalaj, mermer ve ağaç işleme makine ve ekipmanlarında kullanılabilmektedir.

## MODEL SEÇİMİ

Makine ağırlığı / montaj ayak sayısı = taşıma Kg/ad.

## ADVANTAGES

- Vibration reduction.
- Easy leveling for machines,
- No anchor bolts to the floor, prevention of machine walking.
- Easy and quick installation.
- Rubber base in high resistance to oils, acids, grease, etc.

## APPLICATIONS

Milling, moulding, printing, stamping machines, wood working machines, packaging equipments, lathes, grinders, presses, die casting, band saws etc.

## SELECT TO MOUNTS

Total machine weight / number of machine supports = load capacity kg/pcs.

KOD Code	D (mm)	Civata Bolt	Civata Boyu Bolt Length	H (mm)	Ayar Mesafesi Leveling Adj.	Taşıma kg / adet Load kg/pcs.
M1	80	M12x1.25	120	38	12	500
M2	120	M16x1.5	120	45	13	1000
M3	160	M20x1.5	170	53	15	2000
M4	160	M20x1.5	170	54	15	4000
M5	200	M20x1.5	170	56	15	5500





# SL SERİSİ

MACHINE MOUNTS  
MAKİNA TAMPONLARI

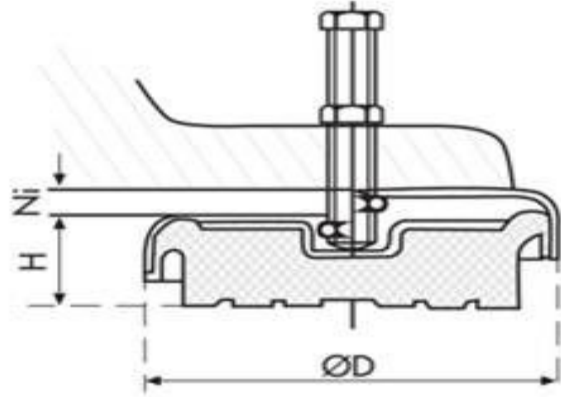

- Kauçuk tabanlı, saç gövde makine denge tamponları.

- Steel cover intern plate and rubber bounding leveling machine mounts.

KOD Code	D (mm)	Civata Bolt	Civata Boyu Bolt Length	H (mm)	Ayar Mesafesi Leveling Adj.	Taşıma kg / adet Load kg/pcs.
SL 080 12	80	M12	100	32	8	300
SL 080 16	80	M16	120	32	8	400
SL 120 12	120	M12	100	35	12	700
SL 120 16	120	M16	120	35	12	800
SL 160 16	160	M16	120	40	12	1200
SL 160 20	160	M20	150	40	12	1500

